

LOC		DIST		P		F		ZONE		LTR		REVISIONS			
BD												DESCRIPTION	DATE	APPD	
												A	REDRAWN ON CAD	5/11/90	-
												B	REV PER EC 0020-246-94	05/17/94	PR
												C	OBSOLETE -1 PER EC 0020-779-95	03 FEB 96	CS

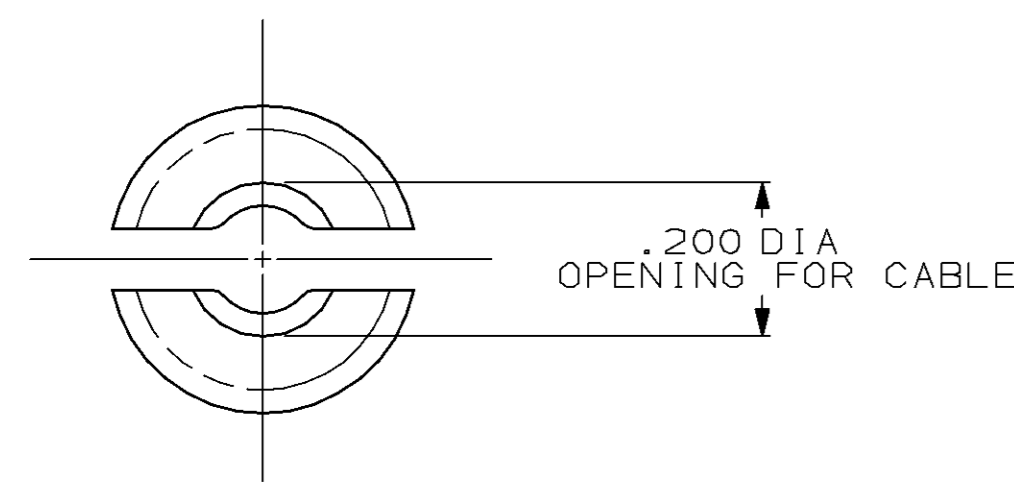

SET 2A

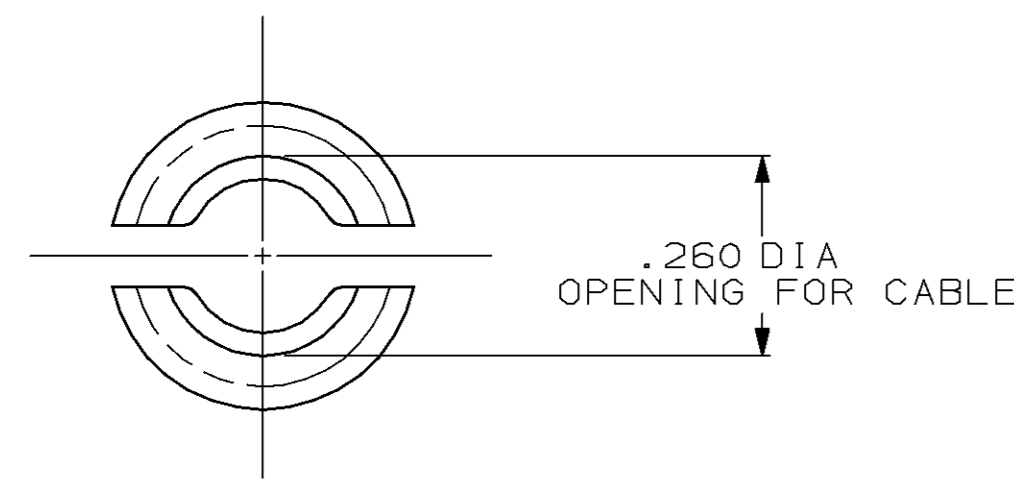

SET 2B

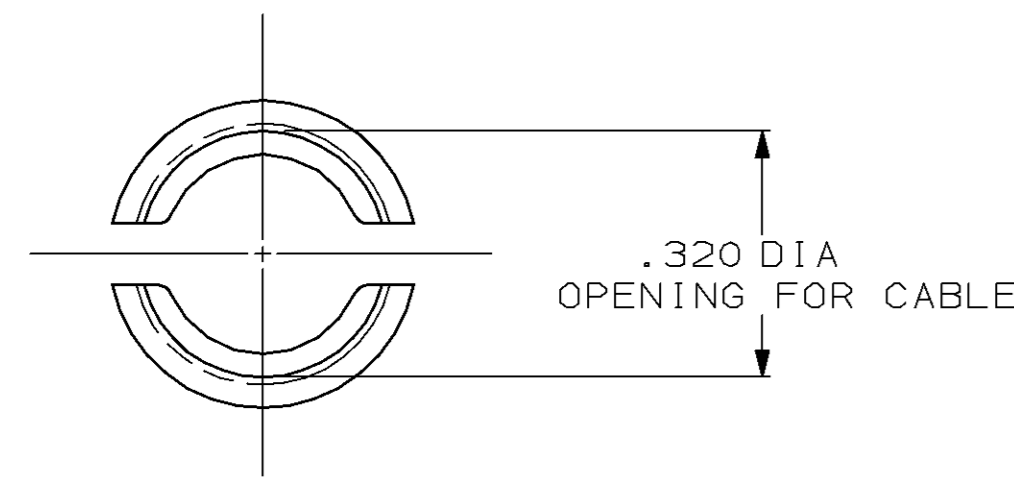

SET 2C

CABLE GATES

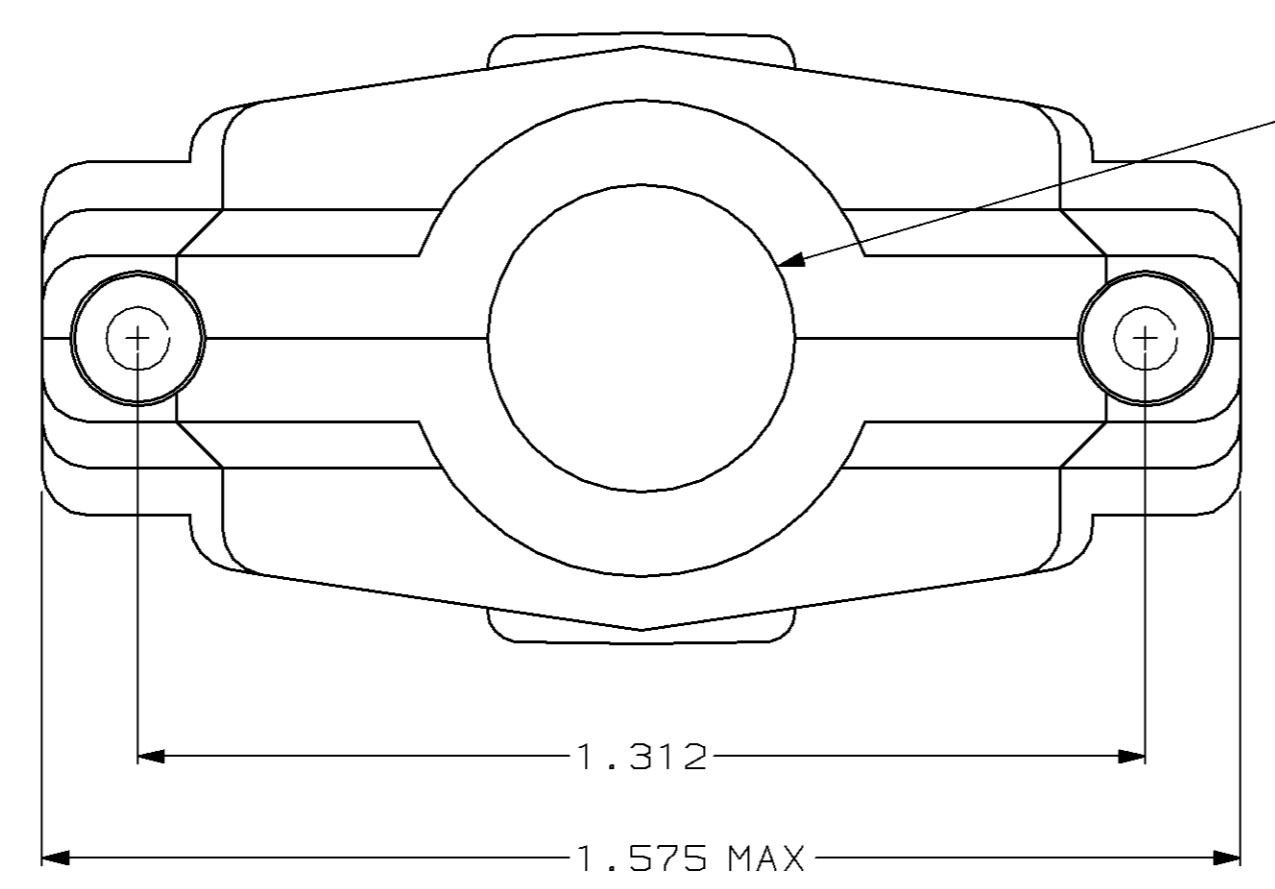

SEE CABLE GATES
 NO CABLE GATE REQUIRED
 FOR .400 DIA CABLE

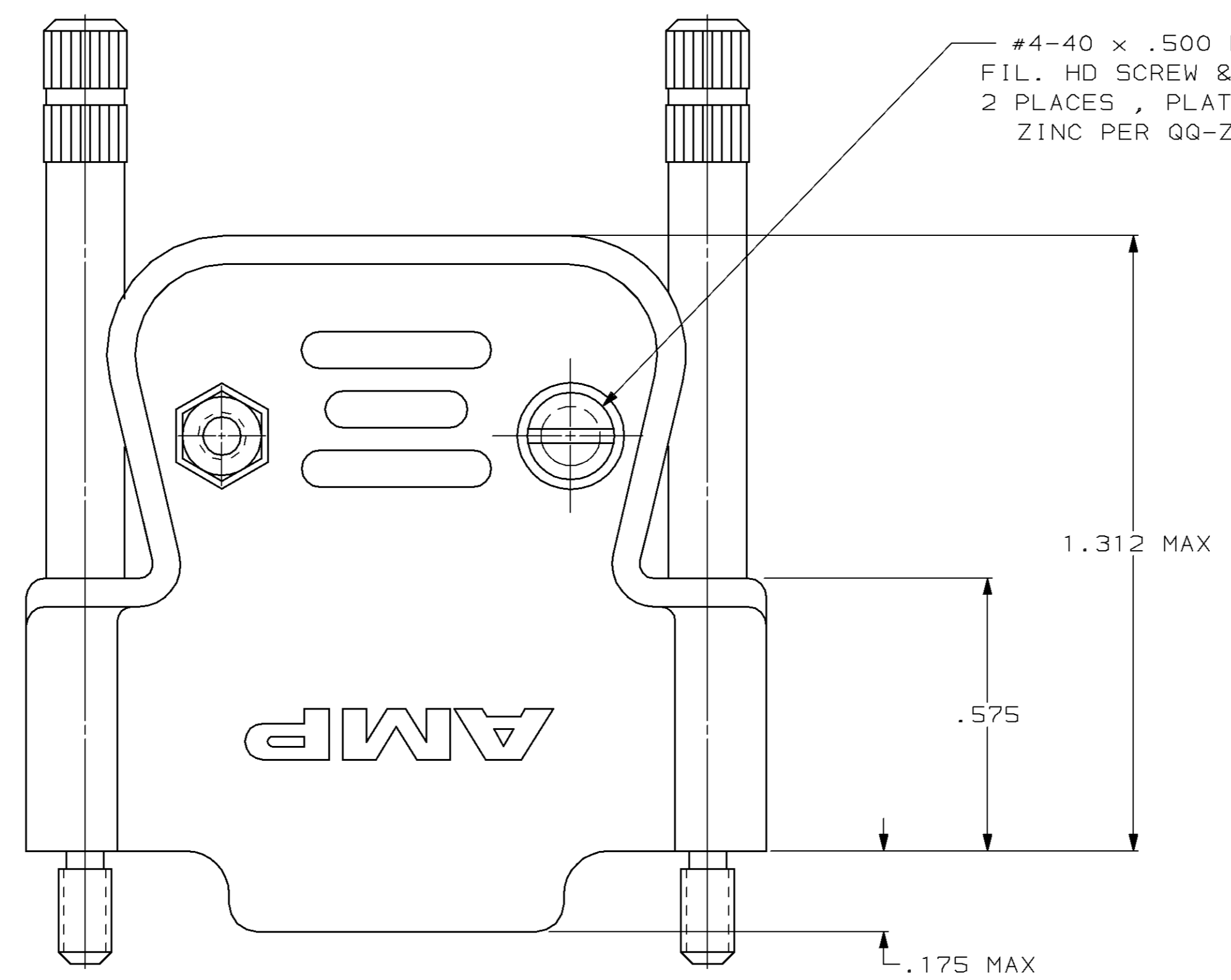

#4-40 x .500 LONG STEEL
 FIL. HD SCREW & HEX NUT
 2 PLACES, PLATED CLEAR
 ZINC PER QQ-Z-325

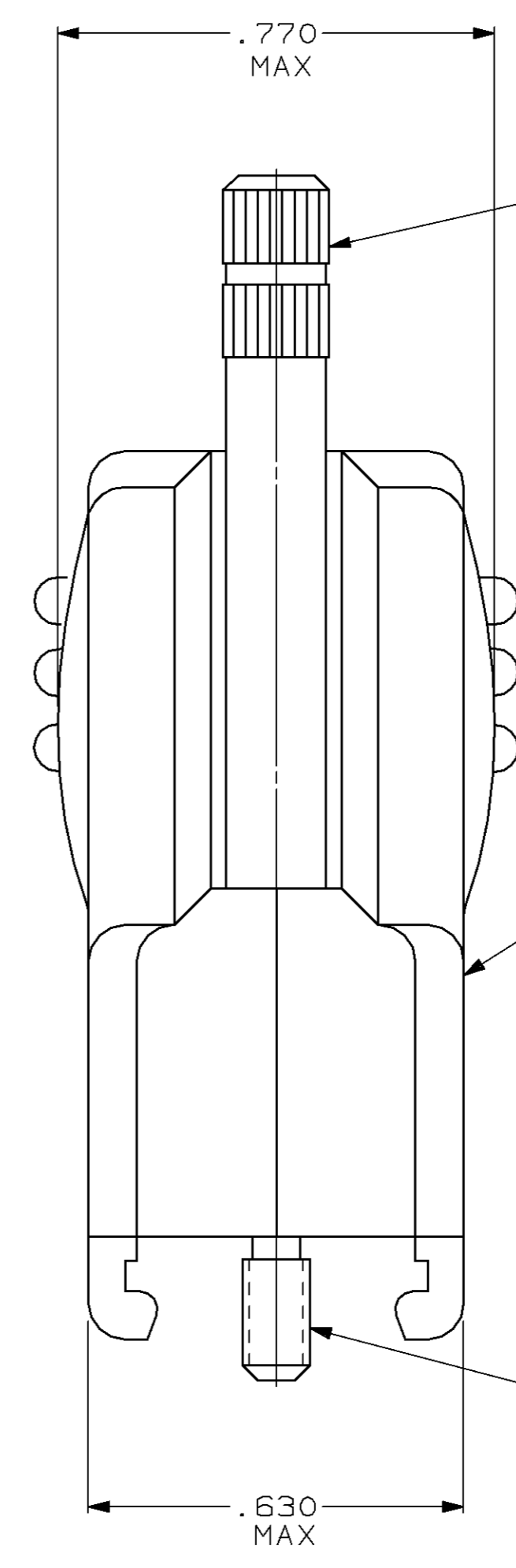

JACKSCREW 2 REQUIRED
 SEE TABLE

CABLE CLAMP, 2 HALVES
 MATERIAL-FLAME RETARDANT
 BLACK NYLON

SEE TABLE FOR THREAD SIZE

- PARTS PACKAGED UNASSEMBLED.
- ZINC PER QQ-Z-325, BLACK.

4-40	PASSIVATED	STAINLESS STEEL	745122-2
M3 x 0.5	2	STEEL	745122-1
SCREW THREAD	FINISH	MATERIAL	PART NO
JACKSCREW			

DO NOT SCALE PRINT. UNLESS SPECIFIED DIMENSIONS IN MILLIMETERS TOLERANCES ON: 2 PLC DEC ± .005 3 PLC DEC ± .005 ANGLES ± .005		DR 5/11/90 A. STAUB BG		AMP INCORPORATED Harrisburg, Pa. 17105	
SEE CALLOUT		CHK 6-15-90 W.G. LENKER			
FINISH SEE CALLOUT		APPD 7-10-90 J. WESTMAN		NAME CABLE CLAMP SIZE 2, 15 POSITIONS CONNECTOR WITH TURNABLE JACKSCREWS, AMPLIMITE™	
MATERIAL		APPD 7-16-90 J. ASSINI		SIZE D 00779	
APPLICATION SPEC		-		DRAWING NO 745122	
WEIGHT		-		SCALE 4:1	
				SHEET 1 OF 1	